

## Department of Electrical and Computer Engineering

### Power Supply Operation

#### The Tektronix CPS 250 Triple Output Power Supply

The Tektronix CPS 250 Triple Output Power Supply is a variable-voltage, triple-output DC voltage source used to provide DC power to electrical and electronic circuits. Front-panel meters are provided to allow coarse monitoring of the power supply's DC voltage and current levels. In addition, short circuit protection circuits are a part of the power supply to protect it from damage due to excessively high currents that might occur because of accidental shorts on its outputs. The key features of the Tektronix CPS 250 Power Supply are summarized in the following table.

**Table 1. Tektronix CPS 250 Power Supply Specifications**

Input Power:	108 to 132 VAC, 50 – 60 Hz
Output Voltage (5V):	$5.0 \pm 0.1$ VDC @ 2.0A maximum
Output Voltage (0-20V):	0-20 VDC @ 0.5A maximum
Tracking Error:	$\pm 0.2\%$ $\pm 20$ mV
Load Regulation (5V):	0.1% + 5 mV
Load Regulation (0-20V):	0.01% + 3 mV
Meter Accuracy:	0-25 VDC $\pm 2.5\%$ full scale 0-600 mA $\pm 2.5\%$ full scale

Figure 1 shows the major controls and features of the Tektronix CPS 250. The descriptions of these features occur below.



## Power Supplies, Digital Multimeters, Breadboards, and Resistors

**12. A Output.** Positive (red) and negative (black) output for independent 0 to 20 VDC, 0.5 A maximum. LED lights when OVERLOAD current limit is reached or exceeded.

**13. B Output.** Positive (red) and negative (black) output for independent 0 to 20 VDC, 0.5 A maximum. LED lights when OVERLOAD current limit is reached or exceeded.

**14. 5 V 2 A Output.** Positive (red) and negative (black) output for fixed 5 volts DC, 2 A maximum. LED lights when OVERLOAD current limit is reached or exceeded.

**15. Chassis Ground Connector.** The green binding post is connected through the power cord to the power receptacle ground.

### Independent Mode Applications

When in INDEPENDENT mode, any one output of each supply may be connected to any single terminal of another supply or to ground. Variable supplies are independently controlled by front panel voltage and current controls. Ground reference is recommended for safety. There are two types of independent mode operation:

- **Series Operation.** A and B supplies (outputs) can be set to give 0 V to 40 V output with the A/B OUTPUTS switch.
- **Parallel Operation.** A and B supplies (outputs) may be set to parallel operation with the A/B OUTPUTS switch. A and B supplies may be operated in parallel to increase current. Refer to Parallel Tracking on page 14.

### Independent Floating

Figure 2 shows each of the three power supply outputs connected to separate loads. In this example the A/B OUTPUTS switch is set to INDEPENDENT. The green coded A VOLTAGE and A CURRENT controls set the level of output A. The brown coded controls set the level for output B. The three outputs are electrically independent. The V and mA meters read A or B output values according to the position of the A/B meter switch.

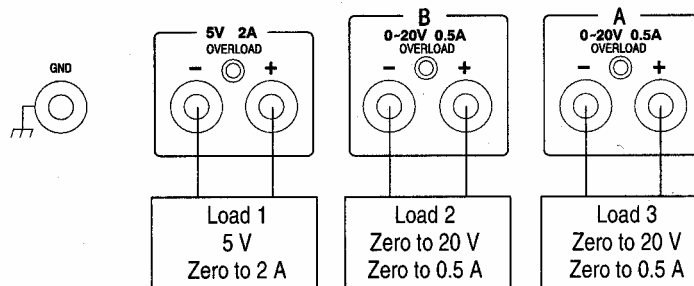

**Figure 2.** Independent Floating Application

To configure the power supply for independent floating, do the following:

1. With the CPS250 Triple Output Power Supply on and the outputs disconnected from loads, set the A and B VOLTAGE controls to the values needed (read on the V meter). Set the A and B CURRENT controls to midrange.
2. Turn POWER to OFF, and connect the load(s).
3. Turn POWER to ON, and readjust voltages if necessary.

## Power Supplies, Digital Multimeters, Breadboards, and Resistors

---

### Independent Ground-Referenced

*CAUTION.* To prevent damage to the equipment when using any ground-referenced output configuration from the CPS250, the circuit or equipment being powered must be isolated from the CPS250s line voltage power source.

Any one of each pair of output terminals, positive (+) or negative (-), may be connected to ground in any combination. There are many possible voltage combinations using the chassis ground as a reference.

**Example 1.** Figure 3 shows an example of a circuit with the +5 volt terminal referenced to ground and both the A and B supplies referenced to -5 V. In this configuration, each of the positive-going 20 V supplies can be varied from -5 V to +15 V (+20 V overall). The GND post becomes the negative terminal for the A and B outputs. The V meter will indicate 0 V when the output is -5 V, 5 V when the output is zero, and 20 V when the output is 15 V. Negative 5 V is taken between GND and the black (-) post of the 5 V, 2 A output. To set up this configuration, proceed as follows:

1. Turn the CPS250 POWER to OFF. Connect the outputs as shown in Figure 3 on page 4.
2. Set the A and B VOLTAGE controls to MIN and the A and B CURRENT controls to midrange.
3. Turn POWER to ON. The V meter should read 0 V in both the A and B position. An external meter connected across the load or load terminals should read -5 V.
4. Turn POWER to OFF, and connect the load(s).
5. Turn POWER to ON, and readjust voltages if necessary.

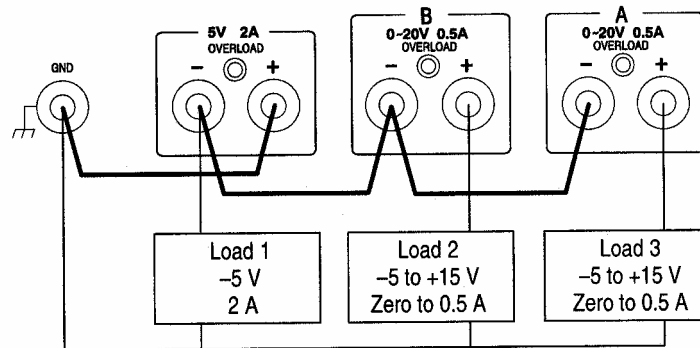

**Figure 3.** Independent Ground-Referenced Application (A)

**Example 2.** This connection scheme is probably the one you will use most often in this lab. Figure 4 shows the power supply connected to produce separate outputs of +5 V, 0 V to +20 V from the B supply, and 0 V to -20 V from the A supply. In this configuration the red terminal of output A is the relative negative terminal because it is connected directly to GND. To set up this configuration, proceed as follows:

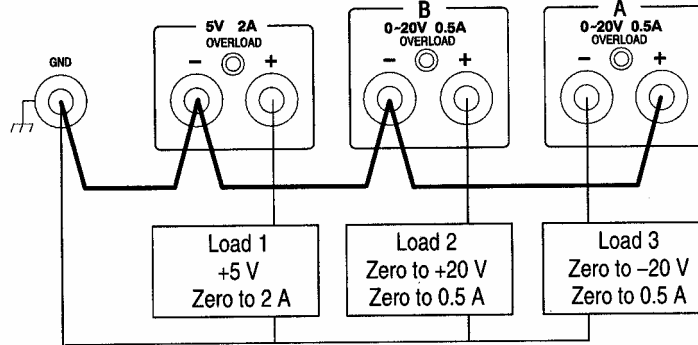

**Figure 4.** Independent Ground-Referenced Application (B)

1. Turn the CPS250 POWER to OFF. Connect the outputs as shown in Figure 4.
2. Set the A and B VOLTAGE controls to MIN and the A and B CURRENT controls to midrange.
3. Turn POWER to ON, and set the desired A and B voltages.
4. Turn POWER to OFF, and connect the load(s).
5. Turn POWER to ON, and readjust voltages if necessary.

**Example 3.** Figure 5 shows the power supply connected in series to produce a variable output of 0 to +40 V, ground referenced, and -5 V, ground referenced. The VOLTAGE and CURRENT controls are in series. The V meter reads only one supply at a time and the mA meter reads total current in either position. To read the total voltage the readings from the A position and B position must be added. To set up this configuration, proceed as follows:

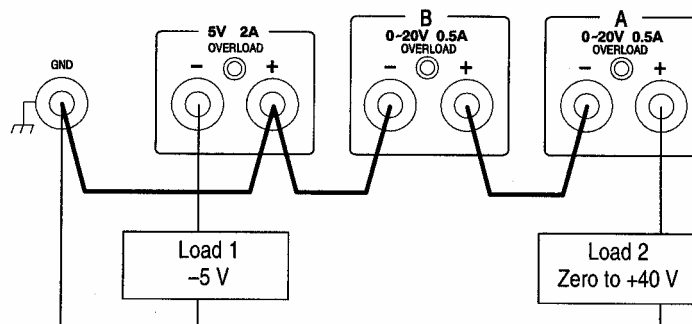
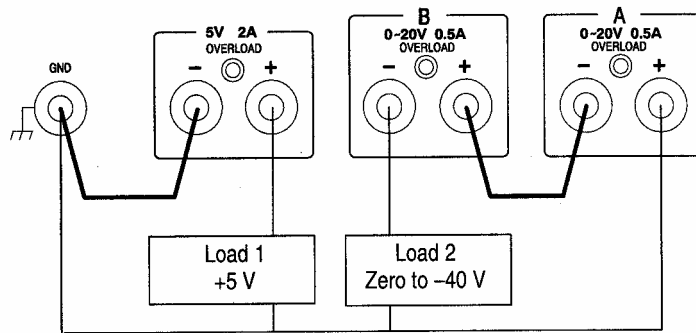

**Figure 5.** Connecting the Two 0-20 V Supplies in Series to Produce 0 to +40V.

## Power Supplies, Digital Multimeters, Breadboards, and Resistors

1. Turn POWER to OFF, and connect the outputs as shown in Figure 5.
2. Set the A and B VOLTAGE controls to MIN and the A and B CURRENT controls to midrange.
3. Turn POWER to ON, and observe the V meter in the A and B positions to set the desired voltage. Remember, the total output is the sum of the two readings.
4. Turn POWER to OFF, and connect the loads.
5. Turn POWER to ON and readjust voltages if necessary.

**Example 4.** Zero to  $-40\text{V}$  and fixed  $+5\text{V}$  outputs are shown in Figure 6. Follow the procedures outlined above to operate this configuration.



**Figure 6.** Connections to Provide Fixed  $+5\text{V}$  and  $0$  to  $-40\text{V}$ .

**Example 5.** Figure 7 shows the configuration for three, ground referenced, negative supplies.

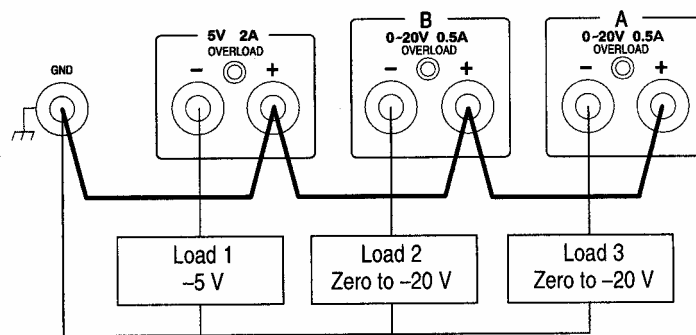

**Figure 7.** Independent Ground-Referenced Applications (Negative output)

**Example 6.** Figure 8 shows the configuration for three, ground referenced, positive supplies.

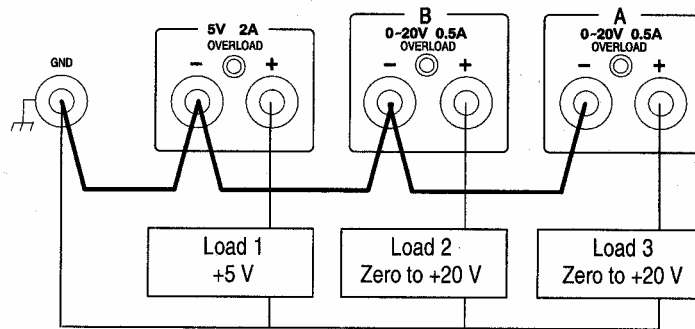
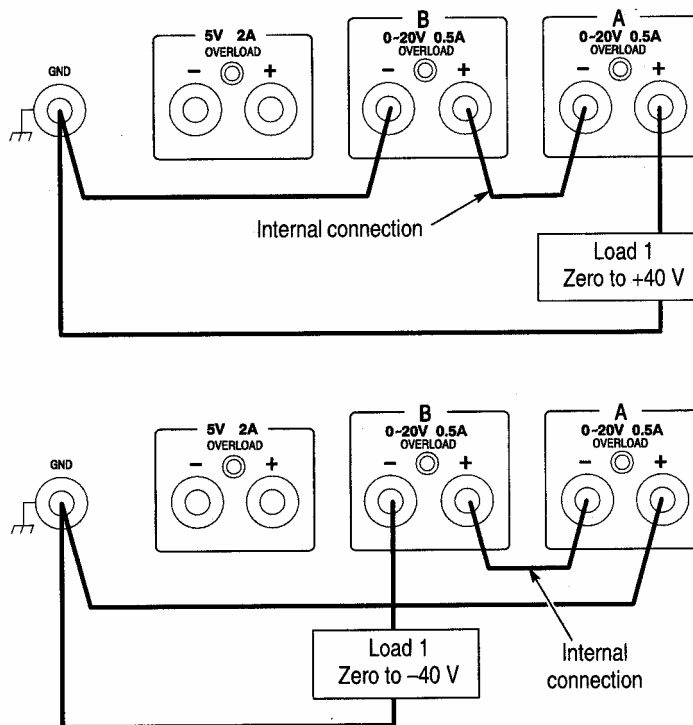

**Figure 8.** Independent Ground-Referenced Applications (Positive output)

### Tracking Mode Applications

#### Series Tracking

When the A/B OUTPUTS selector is set to SERIES TRACKING, the -output of the A variable supply is connected internally to the +output of the B variable supply. When set to the SERIES TRACKING mode, the output may be floating or ground referenced. However, only one terminal of the two variable supplies may be grounded. These options are shown in Figure 9. The output voltage and current are controlled by the A VOLTAGE and A CURRENT controls. For convenience, set the B VOLTAGE and B CURRENT controls fully clockwise to avoid the B supply shutting down. The 5 V fixed supply may be independently grounded or allowed to float.



**Figure 9.** Series-Tracking Applications

**Parallel Tracking**

When the A/B OUTPUTS selector is set to PARALLEL TRACKING, the + outputs of the A and B variable supplies are connected and the – outputs of the A and B variable supplies are connected. The resulting combination is a single supply capable of providing 0V to 20 V and up to 1.2 A. Control is provided by the A VOLTAGE and A CURRENT controls. The B VOLTAGE and B CURRENT controls should be set fully clockwise. The parallel output may be floating or ground referenced, but only one terminal (+ or –) may be at ground reference. Those options are shown in Figure 10. The 5 V fixed supply may be independently grounded or allowed to float.

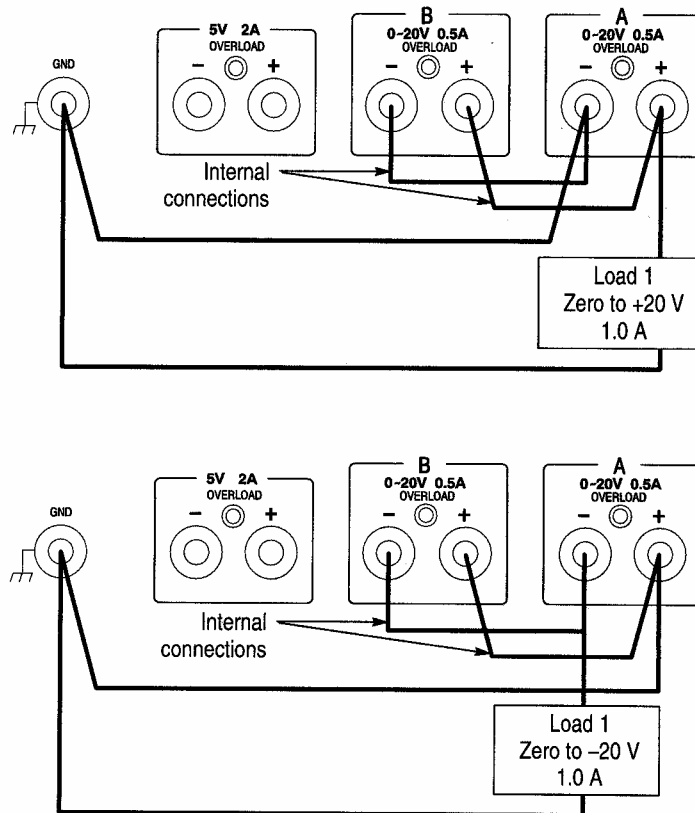

**Figure 10.** Parallel-Tracking Applications